

SCHEMATIC (NON-SHORTING)

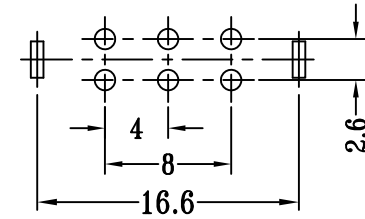
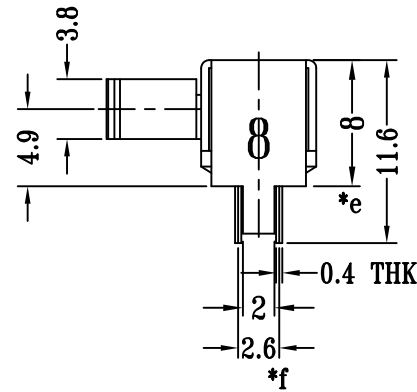
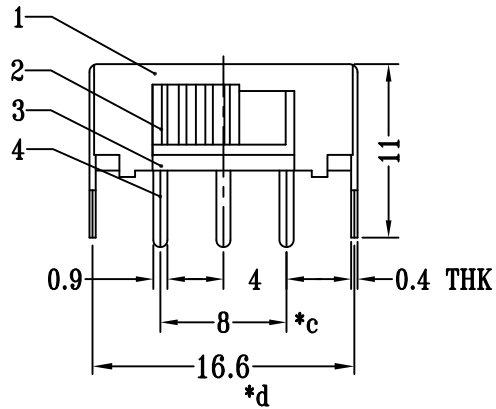

**P.C.B LAYOUT
BOTTOM VIEW**

注：“*”表示关键尺寸（6个）

NO.	PARTS	MATERIALS	Q'TY	FINISH	TOLERANCE UNLESS SPECIFIED					
8					WITHIN 1.5mm	±0.1mm	A	2019-8-21	初版	
7					OVER 1.5mm	±0.2mm	ISSUE	DATE	DESCRIPTIONS OF REVISION	
6	SPRING	STEEL WIRE	2	NATURAL	TITLE : VERTICAL SLIDE SWITCH			UNIT : mm	DRWG NO.:	
5	CONTACT	BRASS STRIP	2	Ag PLATED	MODEL: SK22F12			SCALE: 2:1	DWN.	2019-8-21
4	TERMINAL	BRASS STRIP	6	Ag PLATED	深圳市金航标电子有限公司		www.kinghelm.com.cn	CHK'D		
3	BASE	PHENOLIC RESIN	1	NATURAL	KH-SK22F12-G5-8		0755-28190160	APPD.	2019-8-21	
2	KNOB	POM	1	BLACK						
1	FRAME	STEEL STRIP	1	Ni PLATED						