

Kinghelm®

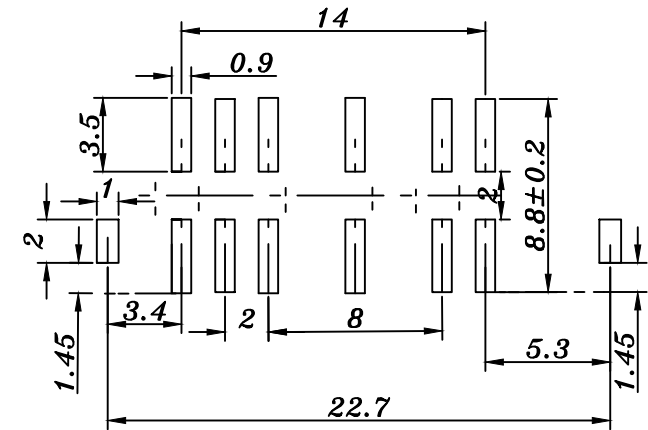

PCB LAYOUT

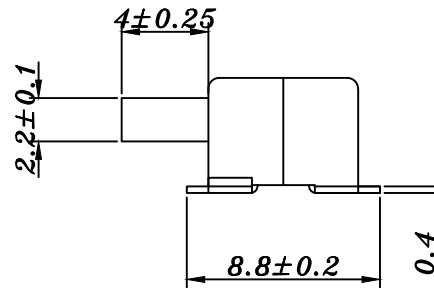
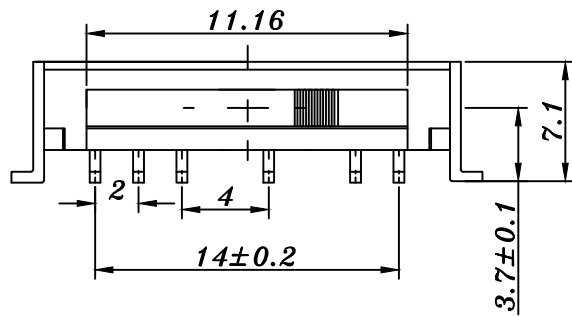
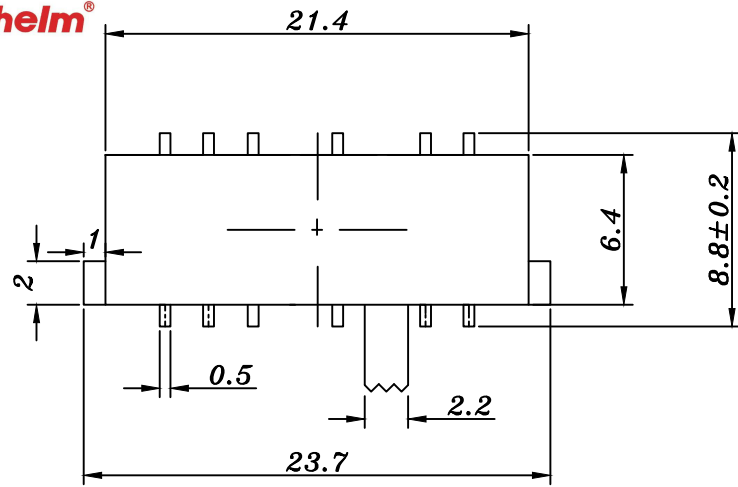
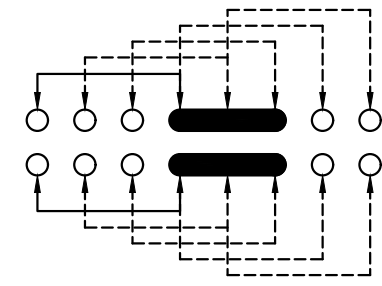

SCHEMATIC (SHORTING)

8					TOLERANCE UNLESS SPECIFIED									
7	STEEL BALL	STEEL	2	NATURAL										
6	SPRING	STEEL WIRE	1	NATURAL	UP TO 5mm:±0.1	ANGULAR	1							
5	CONTACT CLIP	PBS STRIP	2	Ag PLATED	ABOVE 5mm:±0.2	±1°	NO	DATE	REVISIONS			BY	APPD	
4	TERMINAL	BRASS STRIP	12	Ag PLATED	TITLE: VERTICAL SLIDE SWITCH			UNIT : MM	ROHS	DWN				
3	BASE	PHENOLIC RESIN	1	NATURAL	MODEL:SK25D08G4			SCALE: 1:1	COMPLIANT	CHK'D				
2	FRAME	STEEL STRIP	1	Ni PLATED	深圳市金航标电子有限公司			www.kinghelm.com.cn			APPD			
1	KNOB	PA66	1	BLACK	KH-SK25D08-G4			0755-28190160			PRO.AGL:		REV : A	
NO.	PART NAME	MATERIAL	QTY	FINISHING										